



SMART DATALOGGERS

WITH REMOTE
MEASUREMENT AND
TELEMETRY FUNCTIONS



SMART DATALOGGERS WITH REMOTE MEASUREMENT AND TELEMETRY F

OVERVIEW



Advanced dataloggers Z-GPRS3, Z-LOGGER3 and Z-UMTS allow to meet increasing data collection's needs as well as real time analysis and IT systems integration that are in line with the new productivity and communication concepts of Industry 4.0 and Internet of Things. These dataloggers, designed to fulfill remote alarm functions, telemetry and data logging, are available with built-in I/O's, supervision and programming software, Ethernet interfaces, RS485 Modbus Rtu serial ports, 2G/3G+ modem and GNSS/GPS/GLONASS receiver. Optionally dataloggers can be combined with Cloud BOX, an IoT / Cloud solution proposed by SENECA that allows you to centralize data, manage remote connections, create multi-user custom supervision pages.

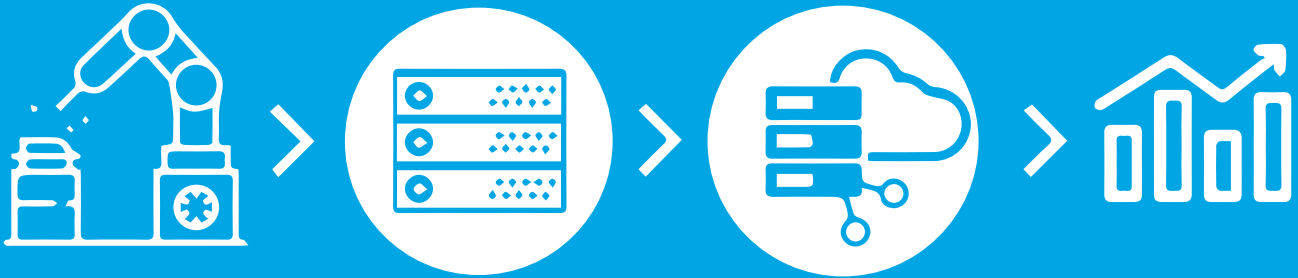

- FIELD MEASUREMENT, DATA COLLECTION, SENSORS /ACTUATORS INTERFACE
- INTEGRATION WITH AUTOMATION SYSTEMS (HMI / SCADA / PLC)
- REMOTE MONITORING, TELEMERY, ALARM MANAGEMENT
- FLEXIBLE PROGRAMMING AND CONFIGURATION

HIGHLIGHTS

<p>SYNCHRONOUS / ASYNCHRONOUS / ON TRIGGER DATALOGGING</p>	<p>DATA REDUNDANCY</p>	<p>ALARM MANAGEMENT VIA SMS/DTMF</p>	<p>SENDING EMAIL / FTP FILE</p>
<p>PROGRAMMING ENVIRONMENT AND CONTROL FUNCTIONS</p>	<p>2G / 3G+ MODEM</p>	<p>BUILT-IN I/O</p>	<p>SERIAL / ETHERNET COMMUNICATION PORTS</p>
<p>MODBUS / IT COMMUNICATION PROTOCOLS</p>	<p>CLOUD SUPPORT</p>	<p>IOT PROTOCOLS (MQTT, HTTP REST) SUPPORT</p>	<p>TRANSPARENT GATEWAY</p>
<p>BACKUP BATTERY</p>	<p>EXPANDABLE MEMORY UP TO 32 GB MICROSD CARD</p>	<p>PUBLIC IP / APN / DYNDNS SIM SUPPORT</p>	<p>UTF8 / UNICOD SUPPORT</p>

HARDWARE

Z-GPRS3, Z-LOGGER3 and Z-UMTS are high-performance units and are configured as a Master unit of Seneca Z-PC Line remote I/O system. They offer powerful security integration with third party systems thanks to Seneca's technological standards. These modules operate with 8 built-in I/O's, 2 serial interfaces with Modbus RTU protocol, 1 Micro USB port and 1 10/100 Mbps Ethernet port. Models with 2G/3G+/GNSS + modem support different types of SIM. These dataloggers are equipped with 8 MB of Flash memory and Micro SD card slot up to 32 GB.



POWER SUPPLY

- 11..40 Vdc; 19..28 Vac
- Power failure battery backup (1hour lifetime)



MODEM

- GSM / GPRS Quad Band (Z-GPRS3)
- 3G+ Worldwide Pentaband (GSM / GPRS / EDGE / WCDMA / HSDPA / HSUPA / HSPA+ / DCHSPA) + GNSS / GPS / GLONASS (Z-UMTS)
- Voice Alarm and DTMF Commands
- Protocols: ftp, smtp, http rest



ETHERNET

- Ethernet interface - ModBUS TCP-IP Client / Server, 10/100 Mbps, RJ45
- Protocols: ftp, smtp, http rest, MQTT



SERIAL INTERFACES

- RS4985/ModBUS Master / Slave COM1 – IDC10 (rear) for I/O expansion
- RS232 / RS485 ModBUS Master / Slave COM2 on terminals



USB

- Micro USB B type host for local programming



CONNECTORS, BUTTONS, LEDES

- Push-push connector for inserting Micro SD card
- On/off button
- Diagnostic LEDES



CPU/MEMORIES

- ARM@32bit
- Multitasking RTOS
- Flash log 8MB
- Slot for Micro SD card up to 32GB



I/O

- 4-CH Digital Input PNP, NPN (counters, totalizers@32bit, max 30Hz)
- 2-CH Analog Input 0..20mA, 0..30V
- 2-CH Relay Output SPT, max 2A, 250 Vac

PROGRAMMING

SENECA's advanced dataloggers ensures a flexible programming allowed by dedicated software designed by Seneca for the development of the control logics (SEAL). These modules are supplemented by an embedded Webserver, an App for SMS commands management, an import and data visualization Tool (Log Factory). Besides, the 'Cloud BOX' HMI allows real-time telemetry, RTU commands sending, log files analysis, events and alarms log archiving through customizable web pages by widget. SENECA offers powerful security integration with third-party Scada systems, Cloud, database and web platforms already available in plants.



SEAL
SYSTEM CONFIGURATION AND LOGIC-MATHEMATICAL FUNCTIONS



CLOUD BOX
REMOTE CONNECTIONS MANAGEMENT, MICRO SCADA, DATALOGGER



WEB SERVER
PARAMETERS MONITORING & SETTING



LOG FACTORY
HISTORICAL FILES STORAGE AND VISUALIZATION



SENECA SMS
ANDROID / IOS APP FOR SENDING AND CUSTOMIZING SMS



THIRD PARTY SYSTEMS
THIRD-PARTY SCADA SYSTEMS, CLOUD, DATABASE AND WEB PLATFORMS



CLOUD BOX - INDUSTRIAL IoT BOX WITH MICRO SCADA FUNCTIONS

WHAT IS CLOUD BOX?



Cloud - IoT solution for data centralization, remote connections management, multi-user custom supervision pages editing.

- Sending commands to advanced dataloggers
- Incoming data storage from field devices into a centralized database
- Access to Cloud BOX through custom web pages

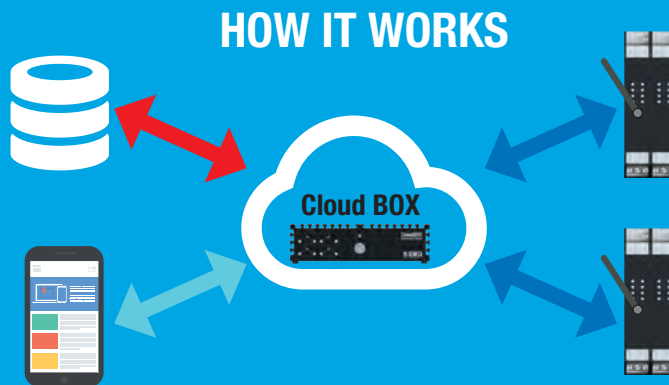

HIGHLIGHTS

SUPERVISION

Editing Web pages with built-in dashboards, synoptics and widgets for field device supervision



DATA STORAGE

Centralized data storage and alarms



DATA VISUALIZATION

Web Page visualization (graphic mode)



EXPORTING DATA

Export data to csv file



HISTORICAL DATA /ALARMS

Historical data, events and alarms web page visualization



SENDING COMMANDS

Sending commands to connected devices bypassing SIM blocks or firewall



REMOTE CONNECTION

Communication management with dataloggers through 2G / 3G+ / Ethernet with HTTP, HTTPS, FTP protocols



SENDING EMAILS

Sending alarm email to an active directory



HMI / SCADA FUNCTIONS



Cloud BOX provides several widgets (input status, chart, bars etc), i.e. element that represent the status of connected devices. From these widgets are achievable responsive web pages (PC, tablet, smartphone) dashboard type (eg. historical data, commands, events management, trend) or supervision interface.

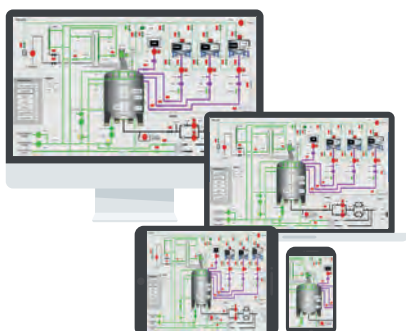

TECHNICAL DATA

Supply voltage	12 Vdc
Operating temperature	0..40°C
Dimension (wxhxd)	185x48x165 mm
Conformity	CE, FCC, RoHS, ErP Ready
Case	Compact / fanless
Mounting	Wall mount or DIN rail
Processor	Intel Celeron J1900 2.0 GHz Quad-Core
SSD	64GB mSATA
LAN controller	Intel 211 AT Gigabit LAN
Interfaces	Nr.4 USB ports, Nr.2 RJ45 ports
Monitoring tools	Dashboard, sinottici, widget
Real-time visualization	Yes
Log, alarms, events	Yes
Sampling time	>1'
Data export	.csv
Connectable Seneca devices	Max 200
Global tags	Max 5.000
Protocols	http, https, Ftp

SMART DATALOGGERS

APPLICATION EXMAPLES

DATA ACQUISITION AND RE-TRANSMISSION

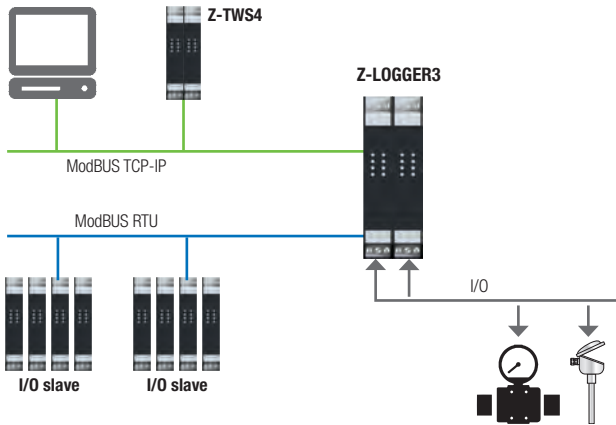

SIMULTANEOUS MASTER / SLAVE OPERATION

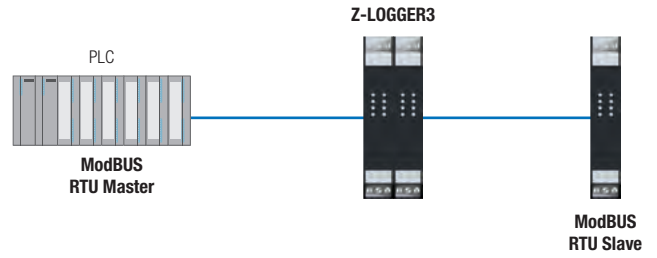

PLC REMOTE MANAGEMENT

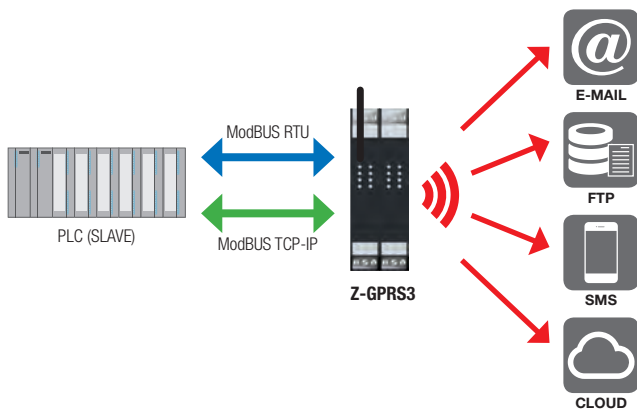

POWER MEASUREMENT, CONTROL AND SUPERVISION

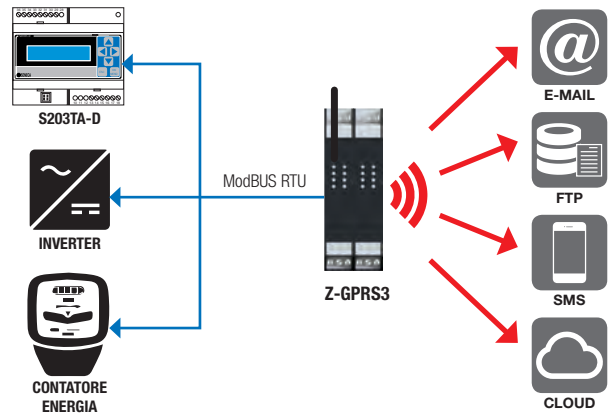

MQTT ARCHITECTURE

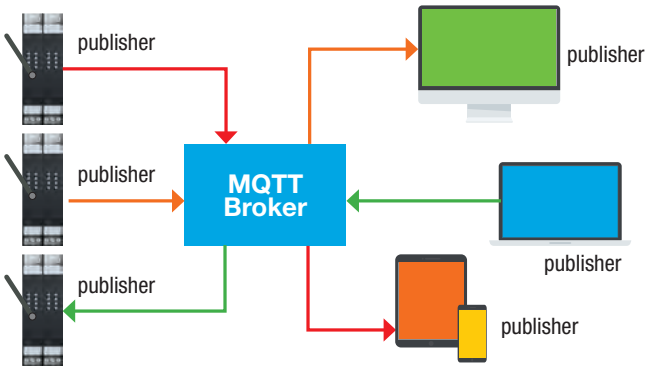

DATALOGGING AND DATA RE-TRANSMISSION

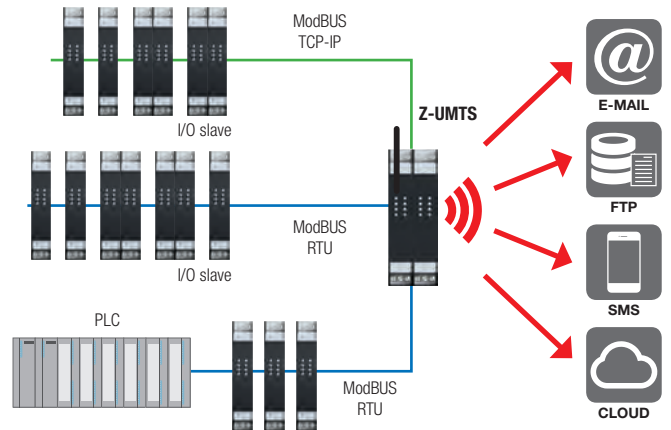

IOT REMOTE MONITORING

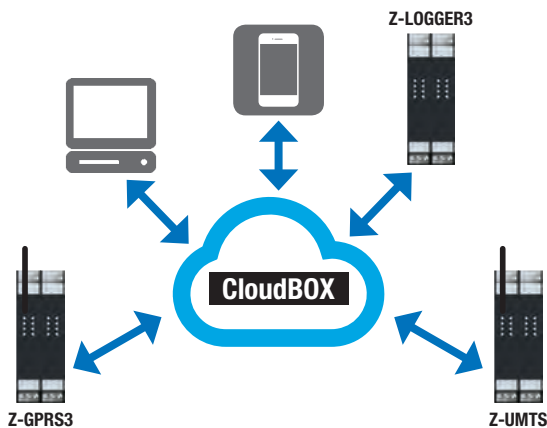

PUMP CONTROL REMOTE MONITORING

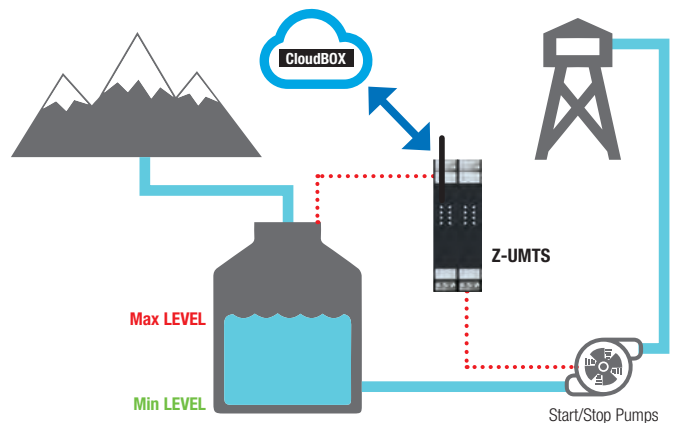

SMART DATALOGGERS

Z-LOGGER3



Datalogger with built-in I/O and alarm management

Z-GPRS3



GSM/GPRS Datalogger with built-in I/O, telemetry functions, voice commands

Z-UMTS



NEW FEATURES

3G+ Datalogger with built-in I/O, telemetry functions, voice commands

GENERAL DATA

Power supply	11..40 Vdc/ 19..28 Vac	11..40 Vdc/ 19..28 Vac	19..40 Vdc/ 19..28 Vac
Power transducers	Yes	Yes	Yes
Power consumption	Max 3,5 W	Max 6,5 W	Max 6,5 W
Built-in UPS	Yes (approx battery life time 60s)	Yes (approx battery life time 60s)	Yes (approx battery life time 60s)
On/Off button	Yes	Yes	Yes
SD remove lock switch	Yes	Yes	Yes
Voice alarms and DTMF commands	No	Yes	Yes
Isolation	1.500 Vac	1.500 Vac	1.500 Vac
Protection degree	IP20	IP20	IP20
Operating temperature	-10..+50°C	-10..+50°C	-10..+50°C
Weight	250 g	280 g	280 g
Dimension (wxhxd)	35x100x112 mm	35x100x112 mm	35x100x112 mm
Mounting	DIN rail	DIN rail	DIN rail

I/O CHANNELS

Digital Input	Nr.4 channels PNP, NPN (counters @32bit up to 30 Hz)	Nr.4 channels PNP, NPN (counters @32bit up to 30 Hz)	Nr.4 channels PNP, NPN (counters @32bit up to 30 Hz)
Analog Input	Nr.2 channels, range 0..20 mA, 0..30 V, 16 bit	Nr.2 channels, range 0..20 mA, 0..30 V, 16 bit	Nr.2 channels, range 0..20 mA, 0..30 V, 16 bit
Digital Output	Nr.2 channels SPDT relay max 2A, 250Vac	Nr.2 channels SPDT relay max 2A, 250Vac	Nr.2 channels SPDT relay max 2A, 250Vac

COMMUNICATION

Ethernet interface	10/100 Mbps (RJ45)	10/100 Mbps (RJ45)	10/100 Mbps (RJ45)
Serial interface #1	RS485 ModBUS, programmable baud rate	RS485 ModBUS, programmable baud rate	RS485 ModBUS, programmable baud rate
Serial interface #2	RS232/RS85 swtchable, programmable baud rate, on terminal	Ftp, Smtp, http rest, https, ModBUS RTU, ModBUS TCP-IP, MQTT	RS232/RS85 swtchable, programmable baud rate, on terminal
USB interface	Micro USB B HOST type (local programming)	Micro USB B HOST type (local programming)	Micro USB B HOST type (local programming)
Protocols	Ftp, Smtp, http rest, ModBUS RTU, ModBUS TCP-IP, MQTT	Ftp, Smtp, http rest, https, ModBUS RTU, ModBUS TCP-IP, MQTT	Ftp, Smtp, http rest, https, ModBUS RTU, ModBUS TCP-IP, MQTT
Modem	-	2G (GSM/GPRS)	3G+ Worldwide Pentaband (GSM / GPRS / EDGE / WCDMA / HSDPA / HSUPA / HSPA+ / DC-HSPA)
GNSS	-	-	GNSS 8th generation, 16-CH GPS, 14-CH GLONASS, accuracy <1,5m CEP-50
Transparent gateway	Yes	Yes	Yes

PROCESSING, DATA STORAGE

CPU	ARM 32 bit	ARM 32 bit	ARM 32 bit
Multitasking RTOS	Yes	Yes	Yes
Flash memory	8 MB	8 MB	8 MB
Expandable datalogging memory	Supplied Micro SD (up to 4 GB) expandable up to 32 GB (dedicated slot)	Supplied Micro SD (up to 4 GB) expandable up to 32 GB (dedicated slot)	Supplied Micro SD (up to 4 GB) expandable up to 32 GB (dedicated slot)
Datalogger	Measurements, alarms, events, logging on Micro SD card and Flash Memory	Measurements, alarms, events, logging on Micro SD card and Flash Memory	Measurements, alarms, events, logging on Micro SD card and Flash Memory
Synchronous Datalogger	Sampling time, min 60s	Sampling time, min 60s	Sampling time, min 60s
Asynchronous Datalogger	Up to 8 triggered-events, max input frequency 1 Hz	Up to 8 triggered-events, max input frequency 1 Hz	Up to 8 triggered-events, max input frequency 1 Hz

SETTINGS

Programming environment	SEAL	SEAL	SEAL
Max number function blocks (SEAL)	32	32	32
Max number variables per device	100+10 built-in I/O	100+10 built-in I/O	100+10 built-in I/O
Web Server	Yes, on Ethernet	Yes, on Ethernet, Private APN / Public IP SIM, DDNS	Yes, on Ethernet, Private APN / Public IP SIM, DDNS

ADVANCED FUNCTIONS

Alarms and Commands	Yes	Yes	Yes
Math functions	Yes	Yes	Yes
Auxiliary functions (DynDNS, Syslogm Unicode/UTF8)	Yes	Yes	Yes
GSM/Ethernet communication lack alarm	No	Yes	Yes
Firmware remote update (ftp, webserver)	Yes	Yes	Yes

STANDARD

Norms	EN 61000-6-4, EN 64000-6-2, EN 61010-1	EN 301511, EN 301489-1/7, EN 60950	EN 61000-6-4, EN 61000-6-2, EN 301511, EN 301489-1, EN 301489-7, EN 60950
-------	--	------------------------------------	---

ORDER CODES

Code	Description	Code	Description
Z-LOGGER3	Datalogger with built-in I/O and alarm management	MSD	Micro SD memory card with adapter
Z-GPRS3	GSM/GPRS Datalogger with built-in I/O, telemetry functions, voice commands	Z-PC-DIN1-35	DIN rail bus system 1 slot 35 mm
Z-UMTS	3G+ Datalogger with built-in I/O, telemetry functions, voice commands	Z-PC-DINAL1-35	DIN rail bus system head terminal + 1 slot 35 mm
CLOUD BOX	Industrial IoT PC Box with HMI functions	Z-PC-DIN4-35	DIN rail bus system 4 slot 35 mm
A-GSM	Dual band swing GSM external antenna, cable 3,2 m, SMA	CU-A-MICROB	USB-A Micro USB-B 5 P plug cable
A-GSM-DIR-5M	GSM-DECT-UMTS directive compact antenna, 5mt cable	Z-SUPPLY	Single-phase switching power supply 24V @ 1.5A
A-GSM-OMNIDIR	GSM-UMTS-WIFI Omnidirectional Antenna	SOFTWARE / APP	
A-GSM-QUAD-N	GSM/3G/4G/LTE high-performance omnidirectional antenna	SEAL	SENECA Advanced language, programming graphic software
FD01	Pulsecap for Energy counter measurement, max freq. 10 Hz	LOG FACTORY	Visualization and log data tool for Z-GPRS3, Z-LOGGER3, Z-UMTS
KIT-USB	Programming toolkit for USB interface instruments	SENECA SMS	Android / iOS App for remote configuration



Headquarters:

Via Austria, 26 - 35127 Padova (I)
T. +39 049 8705.359 - F. +39 049 8706.287
info@seneca.it - www.seneca.it

Technical data, diagrams and drawings in this document are indicative only and not binding